

# UTILITY HIGHBAY

BL400PHB/BL400PHBQ

Cat. #		Approvals
Job	Type	



### APPLICATIONS

- Warehouses, workshops, auto maintenance, factories, etc.
- For applications with ceiling heights of 15-30 ft

### SPECIFICATIONS

- Die-cast housing with protective white powder paint finish
- Easy wiring hanger for 3/4" conduit
- Cast safety hook included for hanging
- 400 watt metal halide, 120/208/240/277 volt, HPF CWA ballast
- Lamp included
- Unit pack
- 16" aluminum reflector with three positions mounting for various distribution spreads.
- Glass bottom lens and retaining clamp band allows use with standard, stock metal halide lamps, Provides lamp image shielding from below.

### LISTINGS

- UL listed for use in damp locations.

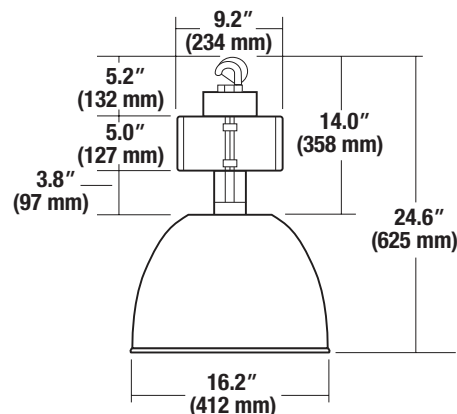

## ORDERING INFORMATION

Catalog Number	Description
<b>BL-400P-HB</b>	Highbay Unit Pack, 400 watt PSMH, Multi-Tap w/ optic, lamp, & hook
<b>BL-400P-HB-Q</b>	Highbay Unit Pack, 400 watt PSMH, Multi-Tap w/ optic, lamp, & hook - QSS

Due to our continued efforts to improve our products, product specifications are subject to change without notice.



Industrial Lighting

Hubbell Industrial Lighting • 701 Millennium Boulevard • Greenville, SC 29607 • PHONE: 864-678-1000

For more information visit our web site: [www.hubbell-ltg.com](http://www.hubbell-ltg.com)